

LUBRICATION ORDER

19 July 1984

(Supersedes LO 5-2420-219-12-1, -2 and -3, 1 November 1970)

**TRACTOR, WHEELED, INDUSTRIAL, D.E.D.,
WIBULLDOZER, SECTIONALIZED (MRS MFG CO.
MODEL 100MC) (4x4) (NSN 2420-00-902-3084)**

Reference: TM 5-2420-219-12, -20, and FEDERAL SUPPLY CATALOG C9100-IL.

Hard time intervals and the related manhour times are based on normal operation. The man-hour time specified is the time you need to do all the services prescribed for a particular interval. Change the hard time interval if your lubricants are contaminated or if you are operating the equipment under adverse operating conditions, including longer-than-usual operating hours. The hard time interval may be extended during periods of low activity. If extended, adequate preservation precautions must be taken.

WARNING

Dry cleaning fluid is flammable. Do not use near a flame or excessive heat. Use only with adequate ventilation. Avoid prolonged breathing of vapors and minimize skin contact.

Clean parts or fittings with dry cleaning solvent (SD), Type II or equivalent. Dry before lubricating. Dotted arrow shafts indicate lubrication on both sides of equipment. A dotted circle indicates a drain below. Relubricate all items found contaminated after fording or washing.

The lowest level of maintenance authorized to lubricate a point is indicated by one of the following symbols as appropriate: Operator/Crew (C); and Organizational Maintenance (O).

Reporting errors and recommending improvements.

You can help improve this manual. If you find any mistakes, or if you know of a way to improve the procedures, please let us know. Mail your letter or DA Form 2028 (Recommended Changes to Publications and Blank Forms) direct to: Commander, US Army Tank-Automotive Command, ATTN: DRSTA-MB, Warren, MI 48090. A reply will be furnished to you.

*The time specified is the time required to perform all services at the particular interval.

*TOTAL MAN-HOURS		*TOTAL MAN-HOURS	
INTERVAL	MAN-HOURS	INTERVAL	MAN-HOURS
10	0.5	250	0.3
50	1.5	1000	1.0
100	1.3		

TA221799

LUBRICANT • INTERVAL

INTERVAL • LUBRICANT

- Crankcase Oil Drain Plug (O)
(Drain and refill)
(See Note 4) **100**
- Front Slack Adjuster (O)
(Remove slotted plug, install fitting, grease and replace plug) **GAA 250**
- Front Brake Camshaft (O) **GAA 50**
- Engine to Transmission Drive Shaft and Slip Joint (C)
(3 fittings) **GAA 50**
- Rear Steering Position Indicator (O) **GAA 10**
- Transmission Shift Levers (C)
(3 fittings) **GAA 50**
- Rear Planetary Drive Level Plug (O)
(Check level)
(See Note 8) **50**
- Rear Planetary Drive Fill and Drain Plug (O)
(Drain and refill)
(See Note 8) **GO C/MR**

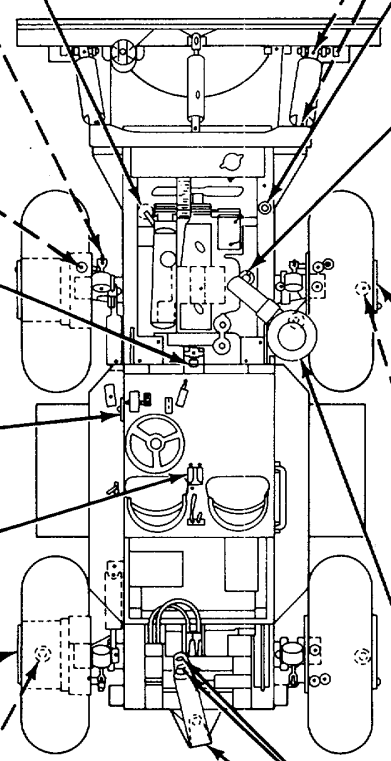

- 10 GAA** Dozer Lift Cylinders (O)
- 100** Engine Oil Filter (O)
(Service)
(See Note 5)
- 10 OE/HDO** Crankcase Level Gage and Fill Cap (O)
(Check level)
(See Note 3)
(See Key)
CAUTION: When OEA oil is used the level will be checked more often.
- 50** Front Planetary Drive Level Plug (O)
(Check level)
(See Note 8)
- C/MR GO** Front Planetary Drive Fill and Drain Plug (O)
(Drain and refill)
(See Note 8)
(See Key)
- 10 OE/HDO** Air Cleaner (C)
(See Key and Note 12)
- 50 GAA** Weight Transfer Cylinder (C)
(3 fittings)

TA221800

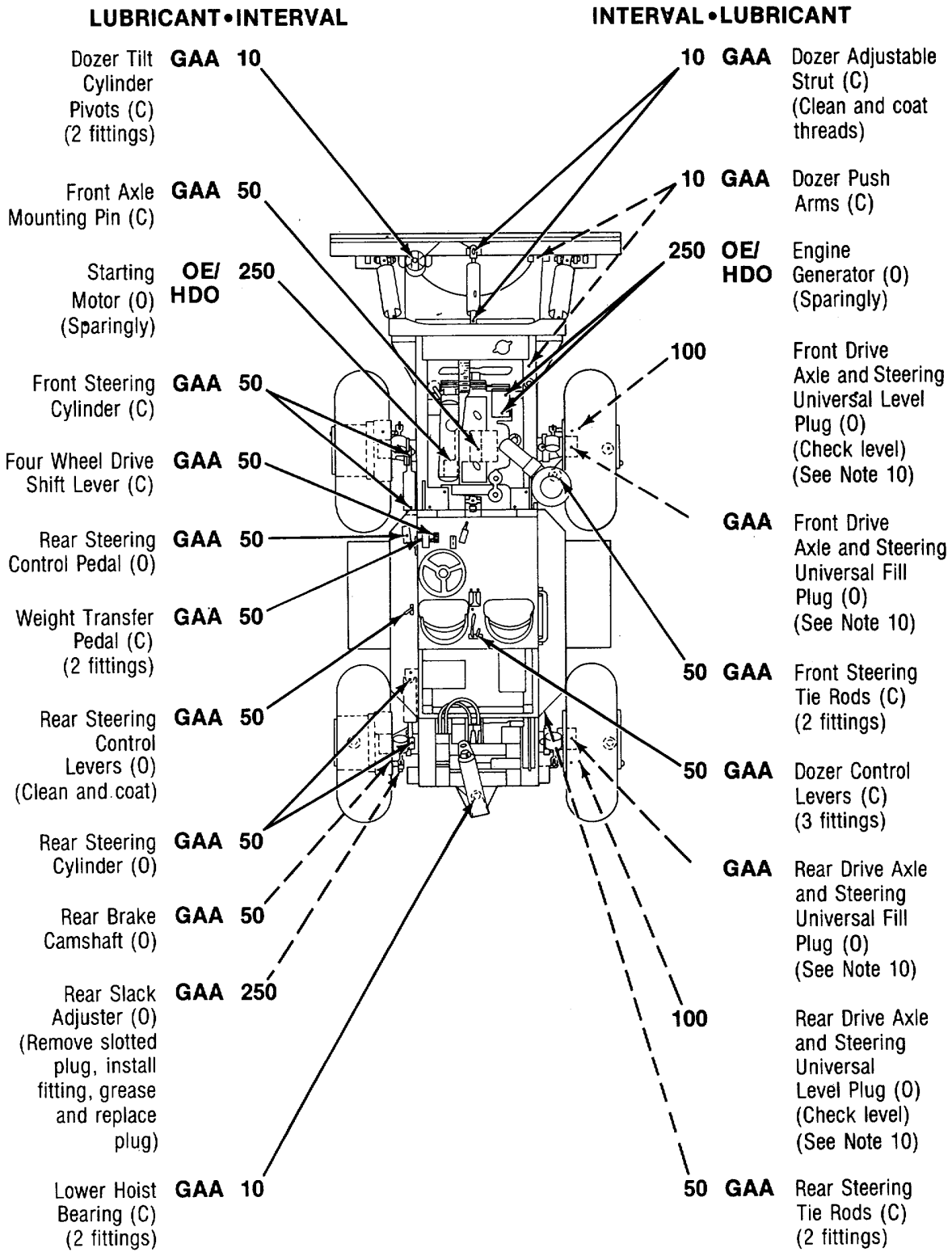

TA221801

LUBRICANT • INTERVAL

INTERVAL • LUBRICANT

Front Differential Fill and Level (O) (Check level) (See Key)

Front Differential Drain (O) (Drain and refill) (See Note 9)

Main and Steering Hydraulic System Filters (O) (Clean) (See Note 7)

Hydraulic Reservoir Drain (O) (Drain and refill) (See Note 7)

Hydraulic Reservoir Fill and Level Gage Cap (C) (Check level) (See Key)

Rear Differential Drain (O) (Drain and refill) (See Note 9)

Rear Differential Fill and Level (O) (Check level) (See Key)

GO 50

C/MR

1000

1000

OE/ HDO

C/MR

GO 50

50 GAA

50 GAA

OE/ HDO

10

1000

1000

50 GAA

50 GAA

Front Axle Drive Shaft (C) (3 fittings)

Front Axle Rear Mounting Pin (O)

Transmission Fill Plug (O) (See Key)

Transmission Level Plug (O) (Check level) (See Note 6)

Transmission Oil Filter (O) (Replace element) (See Note 6)

Transmission Drain Plug (O) (Drain and refill) (See Note 6)

Rear Axle Drive Shaft (C) (3 fittings)

Pintle Hook (C) (3 fittings)

TA221892

LUBRICANT • INTERVAL

INTERVAL • LUBRICANT

Winch Control Levers (O) **GAA 50**

50 GAA Winch Control Cables (C) (4 fittings)

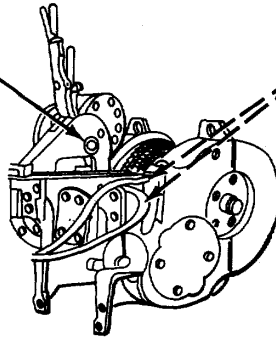

WINCH LEFT VIEW

Hydraulic Motor Shaft (O) **GAA 50**

GO Winch Fill Plug (O) (See Key)

Winch Level Plug (O) (Check level)

50

50 OE/HDO Winch Cable (O) (Clean and coat)

CAUTION: Allow sufficient time for oil to equalize in gearboxes before an accurate check can be made.

WINCH RIGHT VIEW

C/MR

Winch Case and Drive Housing Drain Plug (O) (Drain and refill) (See Note 11)

***-KEY-**

LUBRICANTS	CAPACITY	EXPECTED TEMPERATURES			INTERVALS
		Above +15° F (Above -9°)	+ 40° F to -15° F (+ 4° to -26°)	+40° F to -65° F (+4° to -54°)	
OE/HDO - Lubricating Oil, Internal Combustion Engine, Tactical Service OEA - Lubricating Oil, Internal Combustion, Arctic - Oil Can Points (See Note 2) - Crankcase	17 qts. (16 L)	OE/HDO 30	OE/HDO 10	OEA (See Note 1)	C/MR - Condition Monitor Intervals given are in hours of normal operation.

For Arctic operation refer to FM 9-207

*See Note 13 for lubricant specification number.

***-KEY-**

LUBRICANTS	CAPACITY	EXPECTED TEMPERATURES			INTERVALS
		Above +15°F (Above -9°)	+ 40°F to -15° F (+ 4° to -26°)	+40°F to -65°F (+4° to -54°)	
- Air Cleaner - Hydraulic Reservoir - Transmission	7 qts. (6.62 L) 120 qts. (113 1/2 L) 22 qts. (20.8 L)				For Arctic operation refer to FM 9-207 C/MR - Condition Monitor Intervals given are in hours of normal operation.
GO - Lubricating Oil, Gear, Multipurpose - Front Planetary Drive - Rear Planetary Drive - Front Differential - Rear Differential - Winch Case and Drive Housing	 8 qts. ea (7.56 L) ea 8 qts. ea (7.56 L) ea 12 qts. (11.35 L) 12 qts. (11.35 L) 14 qts. (13.24 L)	GO 80W/90	GO 80W/90	GO 75W0	
GAA - Grease Automotive and Artillery		ALL TEMPERATURES			

*See Note 13 for lubricant specification number.

NOTES:

1. FOR OPERATION OF EQUIPMENT IN PROTRACTED COLD TEMPERATURES BELOW -15°F (-26°C). Remove lubricants prescribed in Key for temperatures above -15°F (26°C). Relubricate with lubricants specified in Key for temperatures below -15°F (-26°C). If OEA lubricant is required to meet the temperature ranges prescribed in the Key, OEA lubricant is to be used in place of OE/HDO-10 lubricant for all temperature ranges where OE/HDO-10 is specified. in the Key.

2. OIL CAN POINTS. Each 50 hours, lubricate yoke pins, ball and socket joints, pivot pins, control linkages and all exposed adjusting threads with OE/HDO.

3. ENGINE CRANKCASE OIL LEVEL HOT OR COLD CHECK. Cold engine, oil level should be at high mark on dipstick. Hot engine, oil level must be between high and low marks on dipstick (allow to set 5 minutes before checking).

4. ENGINE. Oil is to be changed each 100 hours. Drain when lubricant is warm.

NOTES - CONTINUED:

5. ENGINE OIL FILTER. Each 100 hours, remove filter element, clean housing and install new element. After installing new filter element, fill crankcase, operate engine for 5 minutes, check housing for leaks, check crankcase oil level and bring to "FULL" mark.

6. TRANSMISSION, TRANSMISSION OIL STRAINER AND OIL FILTER. Check level each 10 hours with engine running at 1000 RPM, oil at operating temperature and transmission in neutral. Maintain oil level at full mark. Oil and oil filter are to be changed each 1000 hours. Drain all oil. Remove filter element, clean filter housing and install new filter element and gasket. Remove oil strainer, clean and install. Refill transmission. With engine running at idle speed, oil at operating temperature and transmission in neutral (to fill lines and converter) add oil to bring to level plug opening. Operate for 5 minutes and check for leaks.

7. HYDRAULIC SYSTEM. Initially 50 hours, thereafter every 1000 hours, drain reservoir, remove, and clean filter elements. Clean housing, install filter elements and fill reservoir. After refill, operate hydraulic system for 5 minutes, check for leaks and bring oil to "FULL" mark.

8. FRONT PLANETARY DRIVE/REAR PLANETARY DRIVE. Check oil level each 50 hours. Rotate wheels until fill and drain is at 12 o'clock position, remove level plug, check level and install level plug. Change gear lubricant only when required by maintenance repair action, contamination by water, or other foreign material. To drain, rotate wheels until drain plugs are at bottom center, remove plug and drain. Rotate wheels back to level point, fill and install plug. After refill, operate for 5 minutes, check for leaks and bring oil to fill plug opening.

9. FRONT DIFFERENTIAL/REAR DIFFERENTIAL. Check level each 50 hours. Change gear lubricant only when required by maintenance repair action, contamination by water, or other foreign material. After refill, operate for five minutes, check for leaks and bring oil level to level plug opening.

10. STEERING/DRIVING JOINT AND UPPER STEERING BEARING. Each 100 hours remove vent and level plug. Check level by inserting a length of wire in level hole. Add GAA through fill hole to fill socket 1/3 full. Do not overfill.

11. WINCH CASE AND DRIVE HOUSING. Check oil level each 50 hours. Change gear lubricant only when required by maintenance repair action, contamination by water, or other foreign material. After refill, operate for five minutes, check for leaks and bring oil level to level plug opening.

12. AIR CLEANER. Each 10 hours refill oil reservoir to level mark. Each 50 hours disassemble entire unit, clean, re-oil and assemble.

13. LUBRICANTS. The following is a list of lubricants with military symbols and applicable specification numbers.

OE/HDO	MIL-L-2104
GO	MIL-L-2105
GAA	MIL-G-10924
OEA	MIL-L-46167
(SD), Type II	P-D-680

Copy of this Lubrication Order will remain with the equipment at all times, instructions contained herein are mandatory.

By order of the Secretary of the Army:

JOHN A. WICKHAM, JR.
General, United States Army
Chief of Staff

OFFICIAL:

ROBERT M. JOYCE
Major General, United States Army
The Adjutant General

DISTRIBUTION:

To be distributed In accordance with DA Form 12-258, Operational Maintenance requirements or Heavy Tractor, Wheeled.

TA221805

